

LOC	DIST	REV	DATE	BY	APPV
A	66				

FEED TYPE MECHANICAL

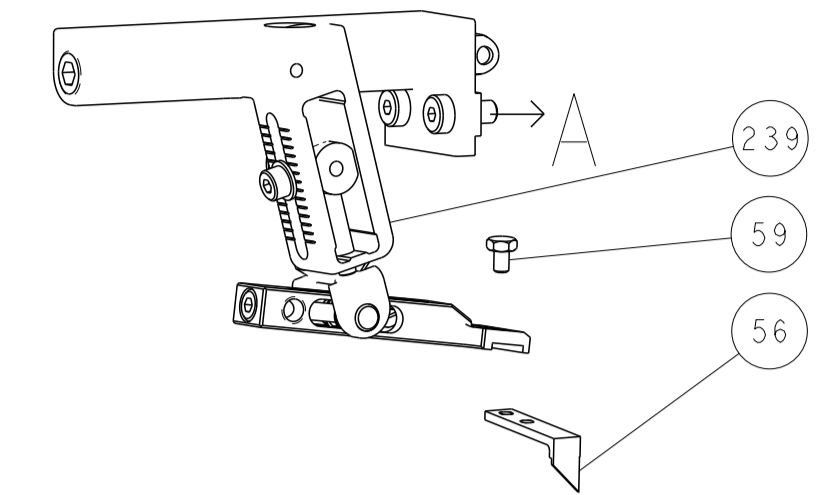

PNEUMATIC

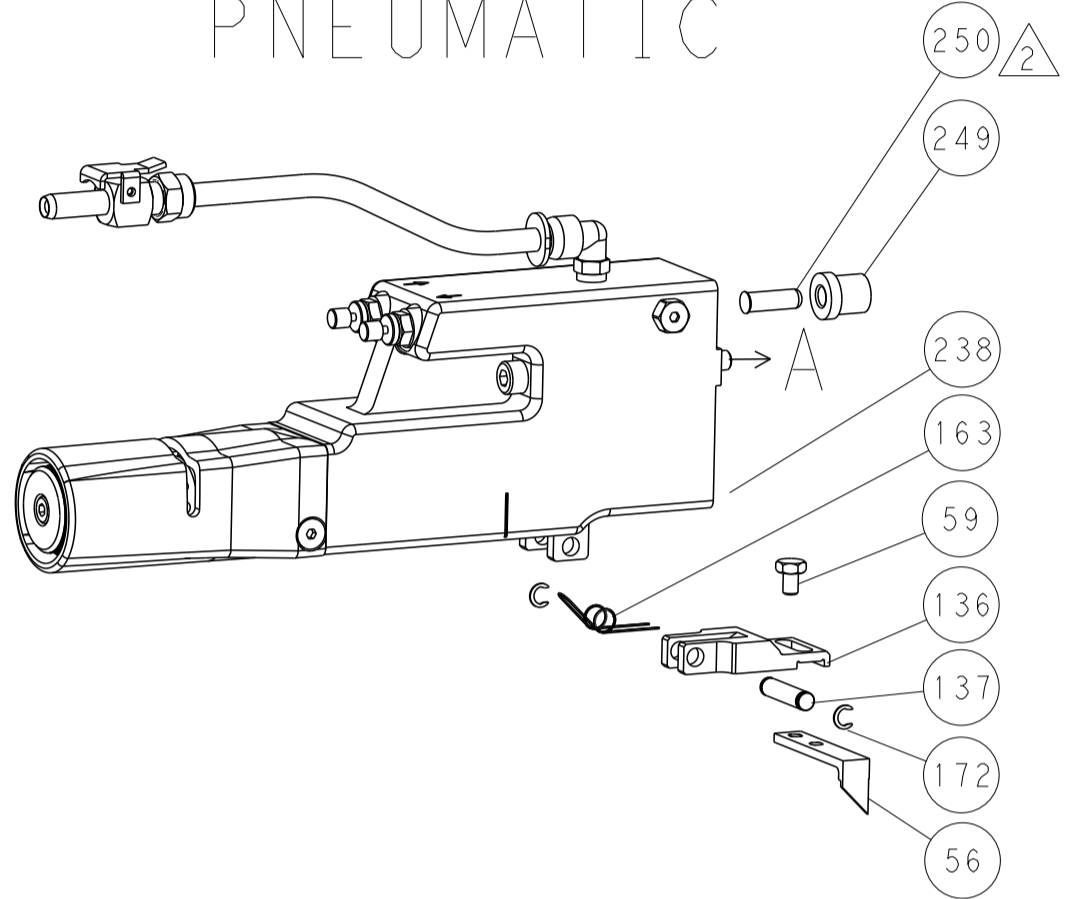

SERVO LATCH PLATE



CAM POSITIONS

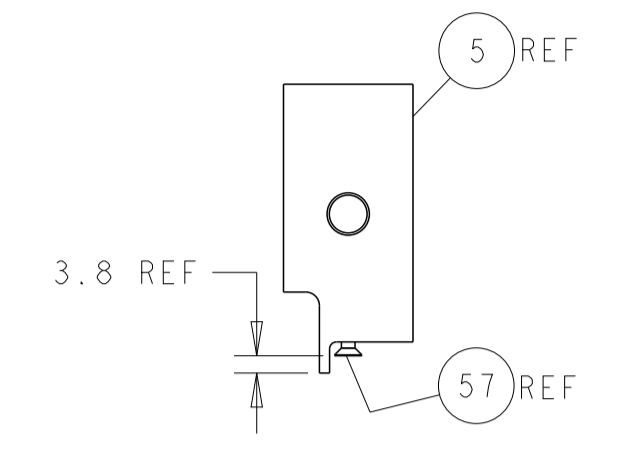
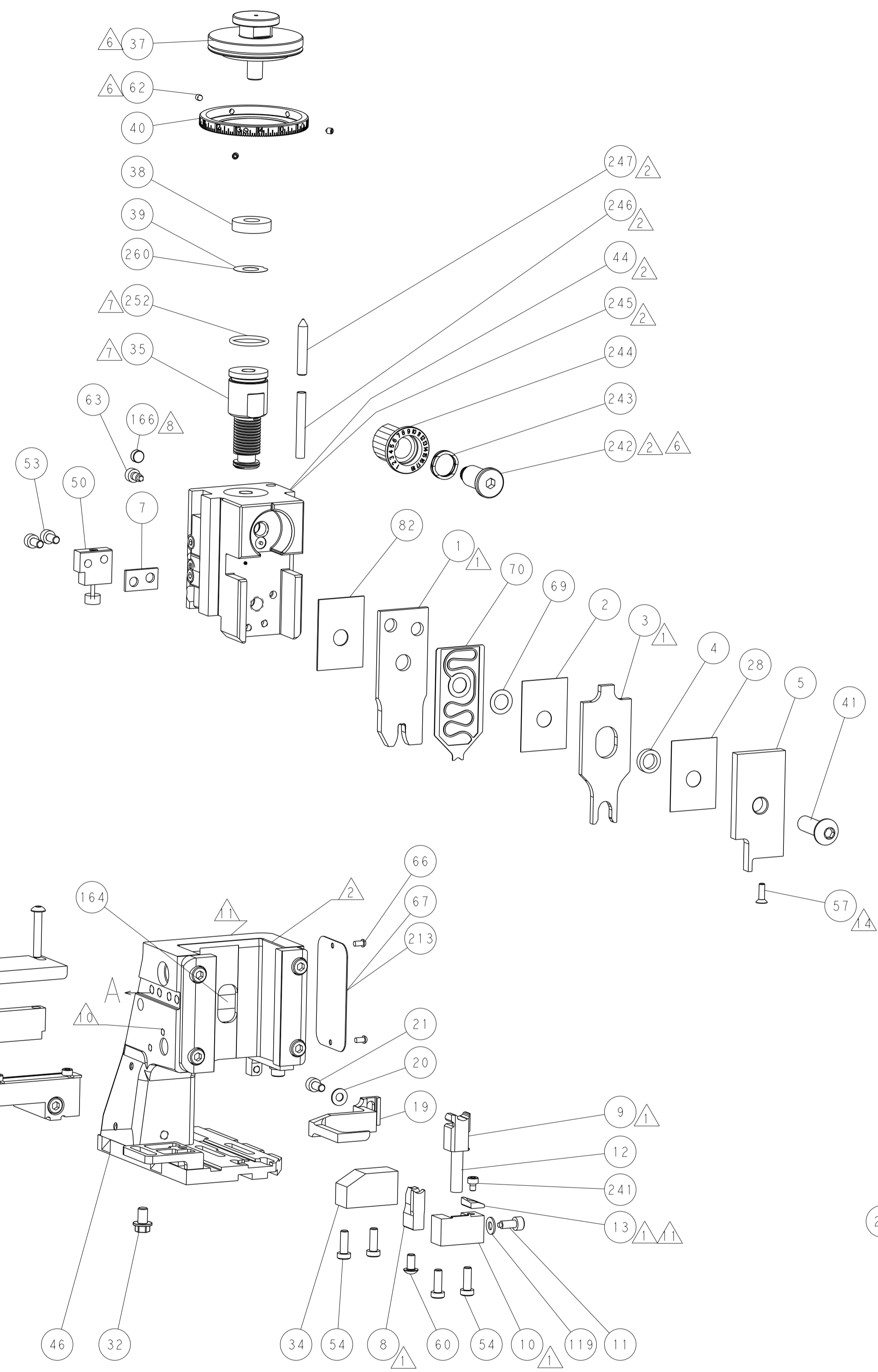

SHEAR DEPRESSOR DETAIL

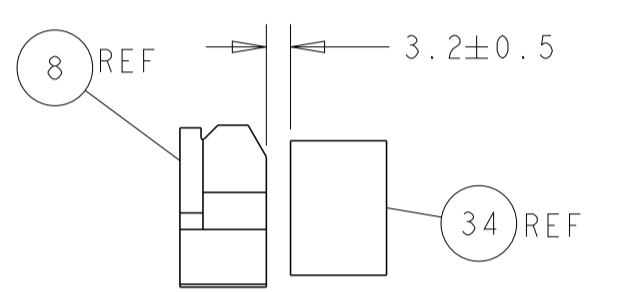

TERMINAL SUPPORT LOCATION

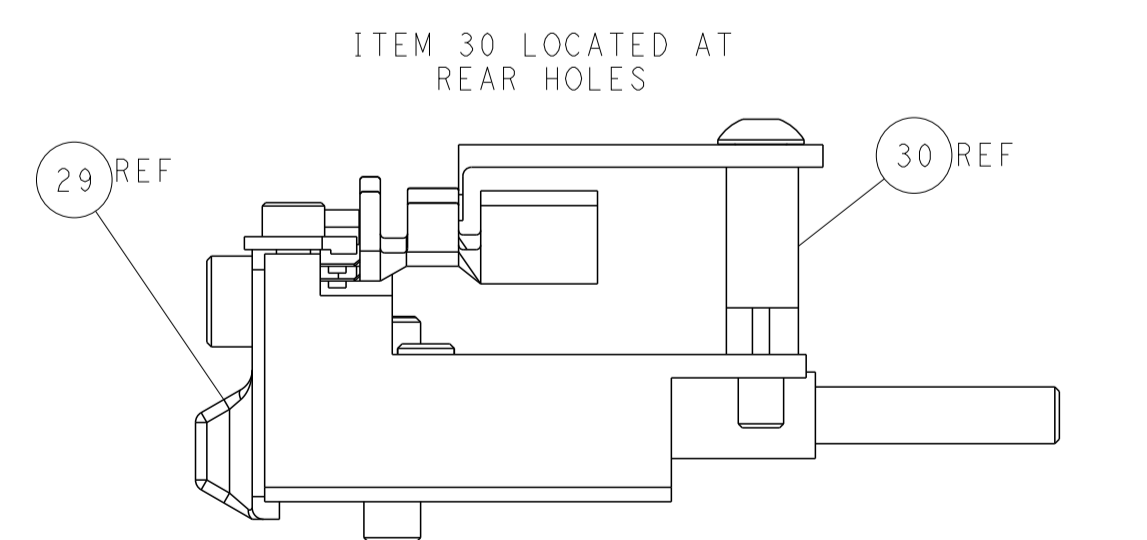

ITEM 30 LOCATED AT REAR HOLES

FEED TRACK POSITION GUIDE BY WIRE BARREL

ATLANTIC VERSION
 Shown on sheets 1 of 4 & 2 of 4
 (Pacific version shown on sheets 3 of 4 & 4 of 4)

DIMENSIONS: mm 		TOLERANCES UNLESS OTHERWISE SPECIFIED: 0 PLC ± 1 PLC ± 2 PLC ± 3 PLC ± 4 PLC ± ANGLES ± FINISH		DWN L. ZHANG 16AUG2011 CHK L. ZHANG 16AUG2011 S. XI 16AUG2011 NAME PRODUCT SPEC APPLICATION SPEC WEIGHT Customer Accessible Production Drawing		TE Connectivity Harrisburg, PA 17105-3608 Ocean Side Feed Applicator SIZE CAGE CODE DRAWING NO A1 00779 C=2151466 SCALE 1:2 SHEET 2 OF 4 REV E	
-----------------------	--	---	--	---	--	---	--

LOC		DIST		REVISIONS			
A	66	P	LTM	DESCRIPTION	DATE	OWN	APVD
-	-	-	-	SEE SHEET 1	-	-	-

FEED TYPE MECHANICAL

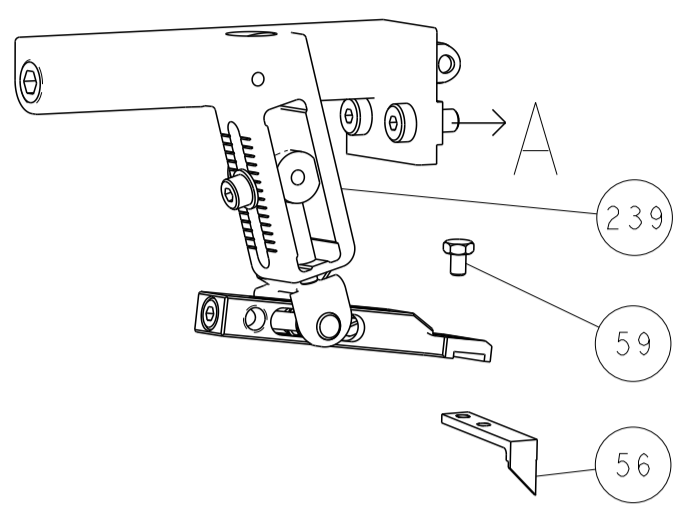

PNEUMATIC

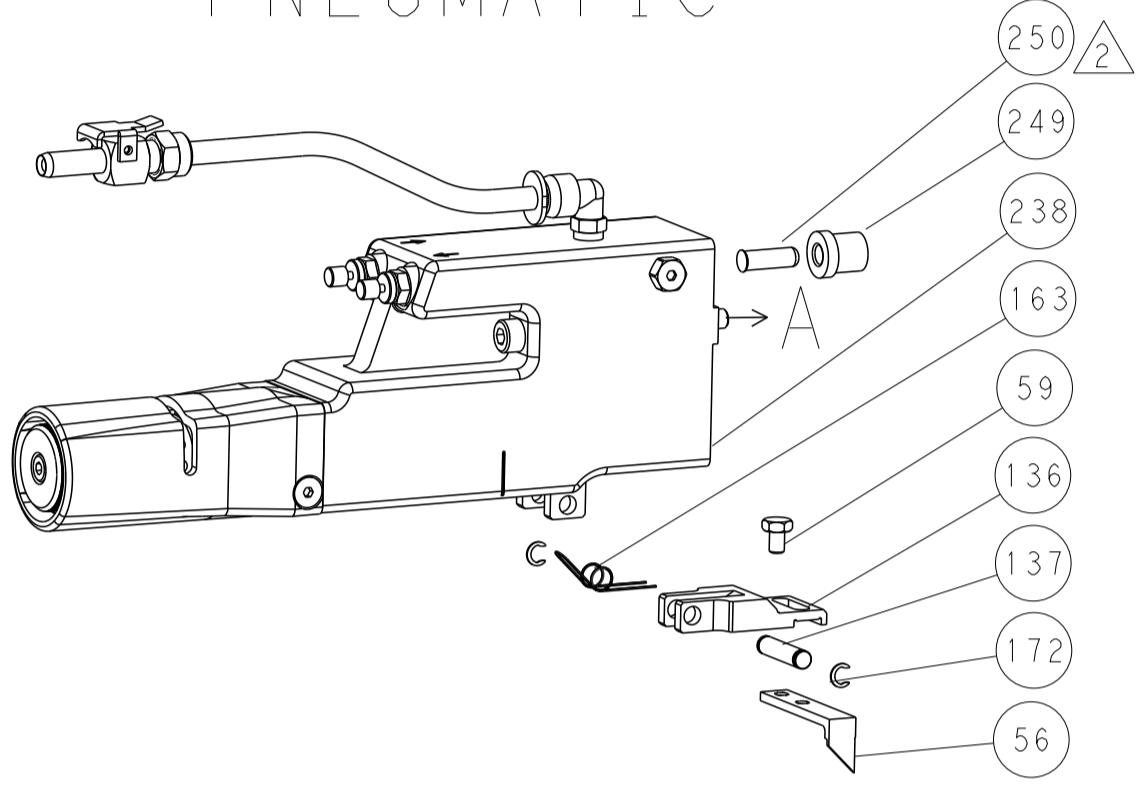

SERVO LATCH PLATE

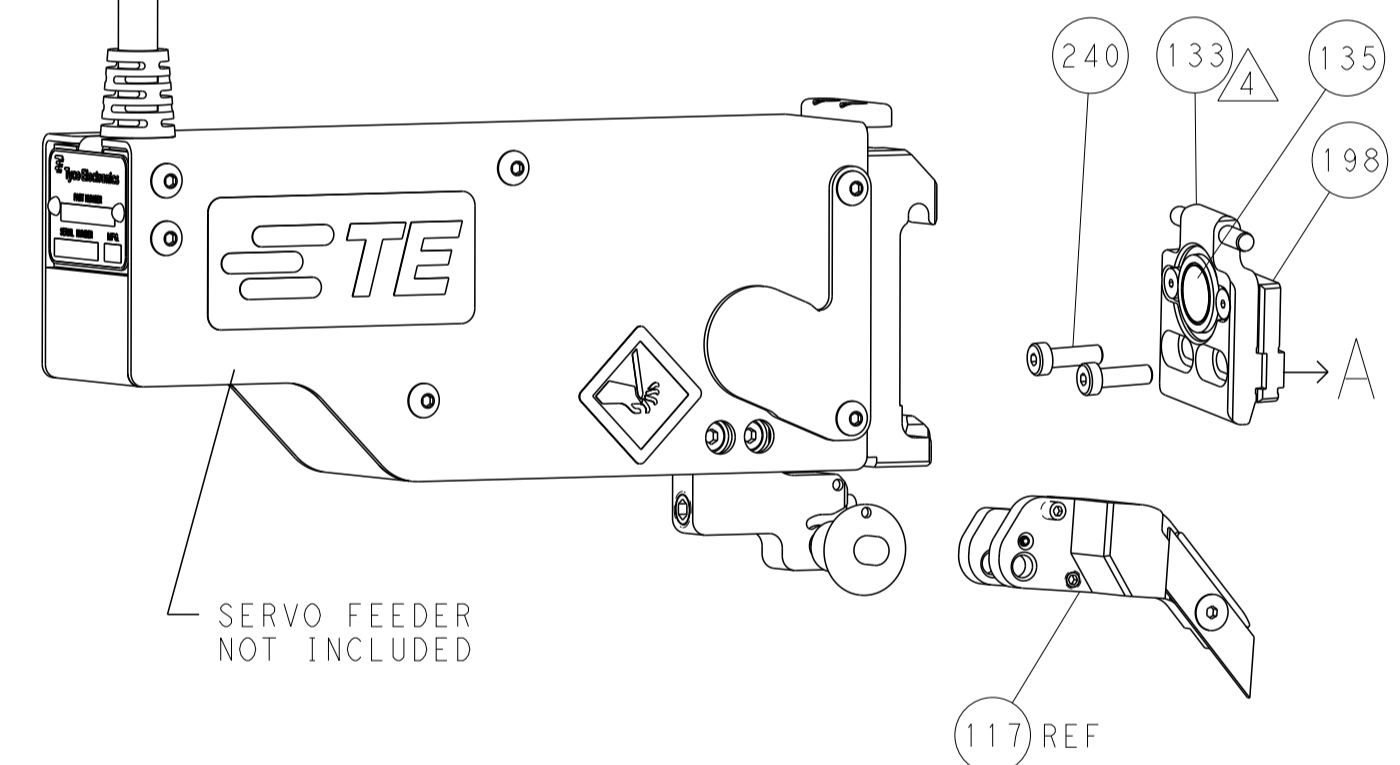

CAM POSITIONS

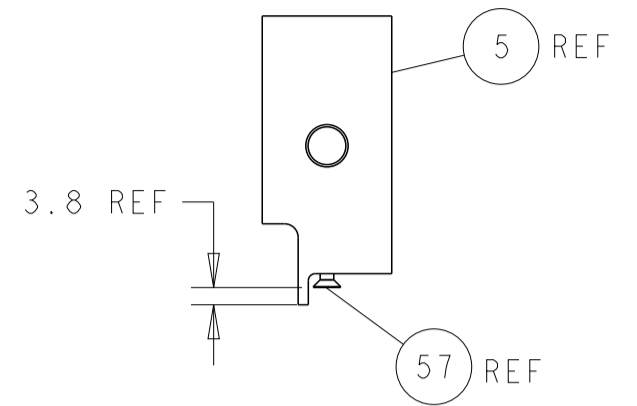
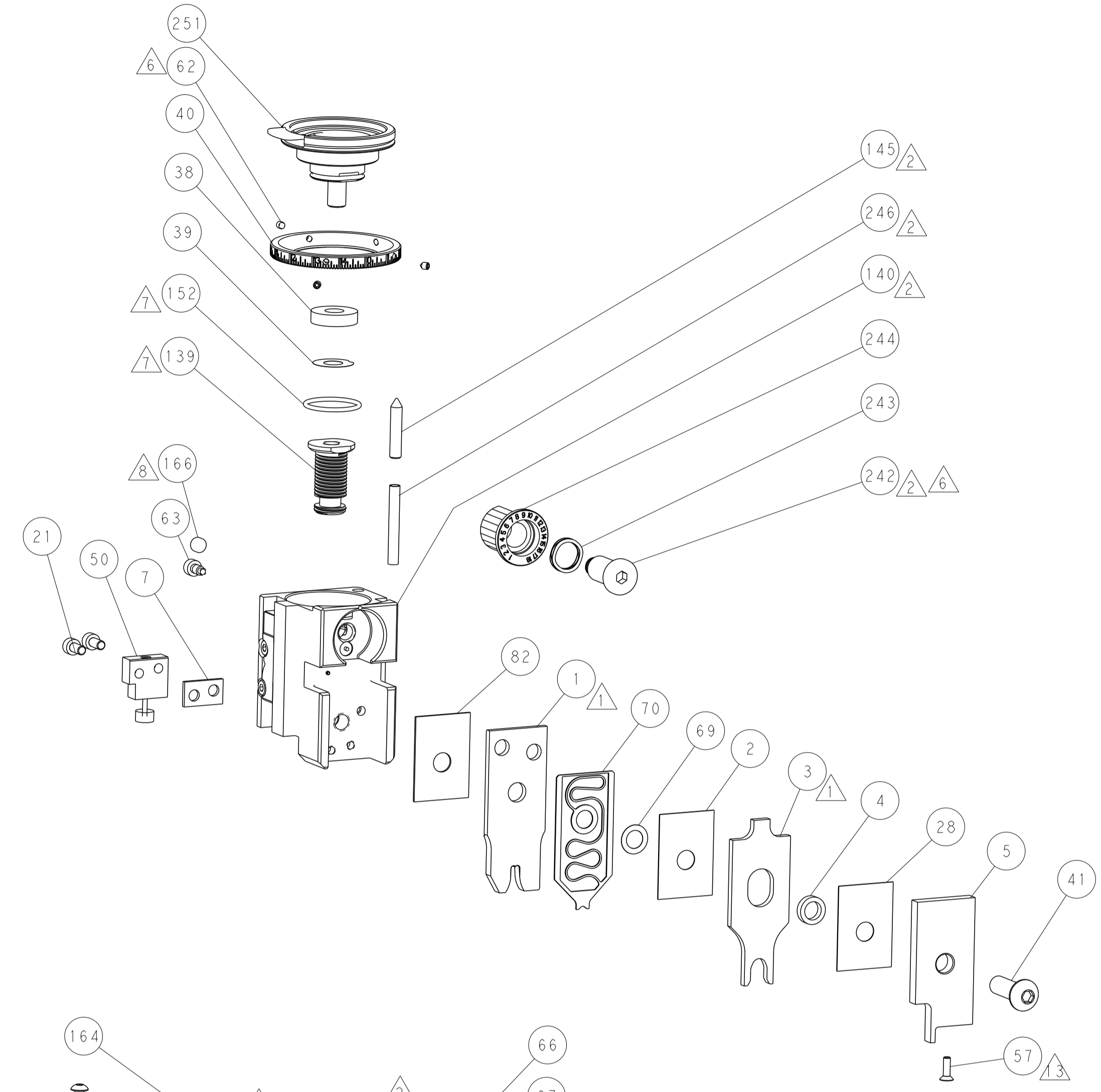
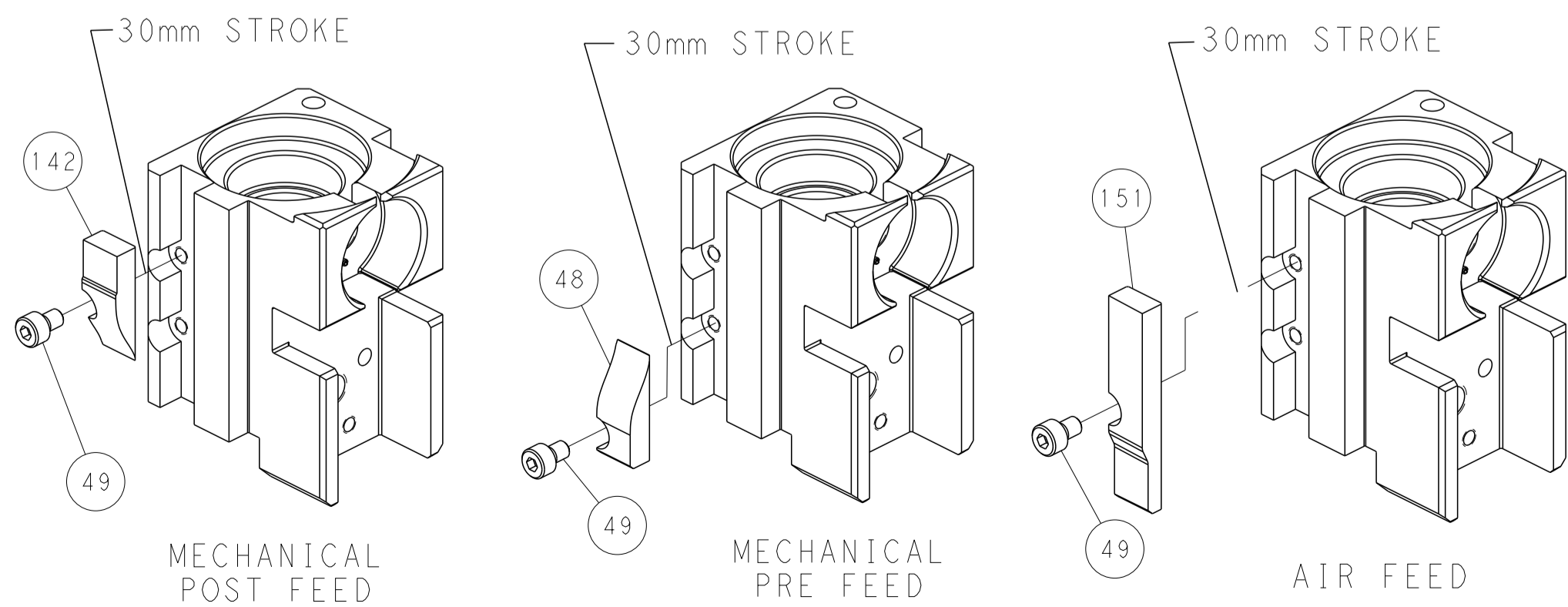

SHEAR DEPRESSOR DETAIL

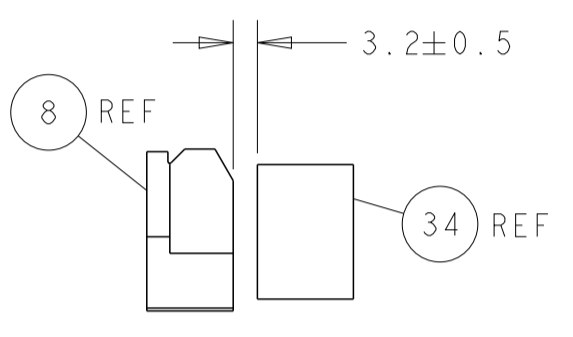

TERMINAL SUPPORT LOCATION

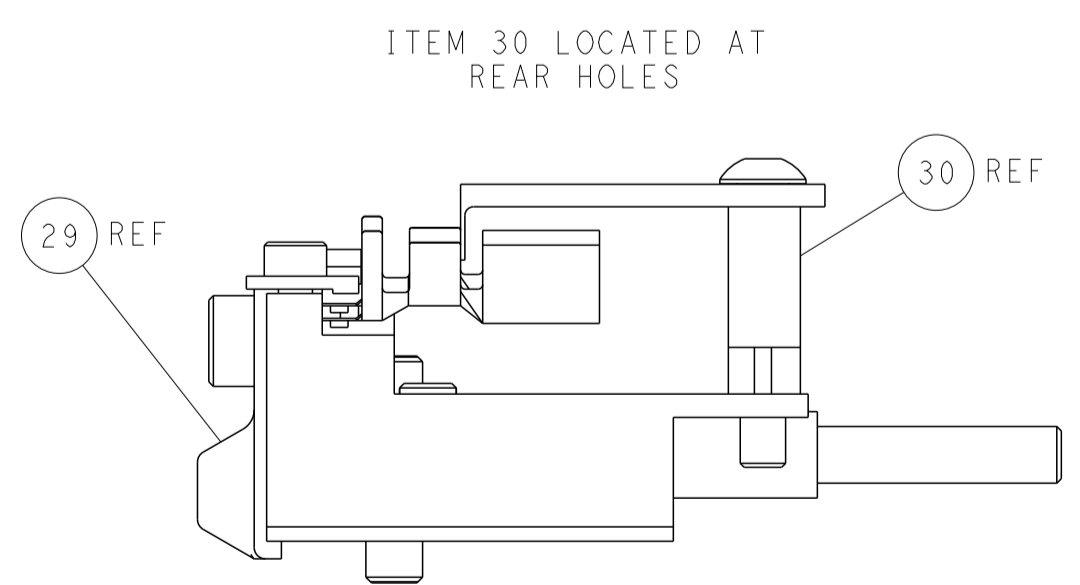
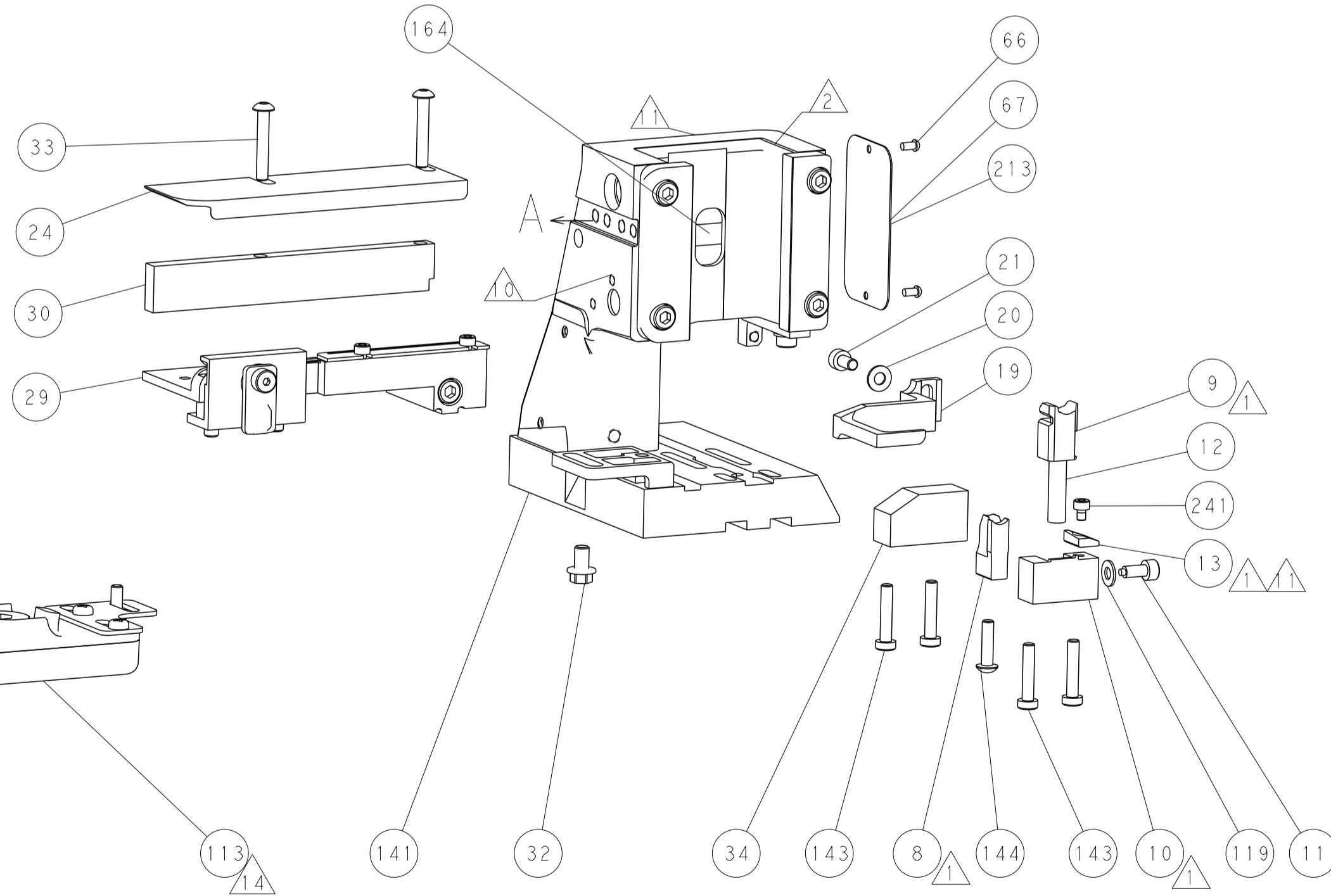

FEED TRACK POSITION GUIDE BY WIRE BARREL

PACIFIC VERSION
 Shown on sheets 3 of 4 & 4 of 4
 (Atlantic version shown on sheets 1 of 4 & 2 of 4)

DIMENSIONS:		TOLERANCES UNLESS OTHERWISE SPECIFIED:		DWN L. ZHANG 16AUG2011		STE Connectivity	
mm	0 PLC ±	1 PLC ±	2 PLC ±	3 PLC ±	4 PLC ±	Harrisburg, PA 17105-3608	
MATERIAL:		FINISH:		APVD S. XI 16AUG2011		NAME	
				PRODUCT SPEC		Ocean Side Feed	
				APPLICATION SPEC		Applicator	
				WEIGHT		RESTRICTED TO	
				A 00779 ©=2151466		SCALE 1:2 SHEET 4 OF 4 REV E	
				Customer Accessible Production Drawing			